

GRADALL

524D

2-section or 3-section boom
MATERIAL HANDLER



524D

SPECIFICATIONS

Performance

Rated Capacity

At 24 in. (610 mm) load center,
6,000 lb. (2,722 kg)

Maximum Lift Height

24.5 ft. (7.5 m) or 32 ft. (9.8 m)

Frame Leveling

8 degrees

Lift Speed (boom retracted)

Empty, 121 f.p.m. (36.9 m/min);
Loaded 79.3 f.p.m. (24.2 m/min)

Boom Speed

Extend 107.5 f.p.m. (32.8 m/min)
Retract 131.3 f.p.m. (40 m/min)

Travel Speeds Forward and Reverse

4WD-2WD 7.5-16 mph (12-25.7 km/hr)

Operating Weight

With 48" (1.2 m) carriage and forks,
524D-2S - 15,320 lb. (6,955 kg)
524D-3S - 15,926 lb. (7,230 kg)

Drawbar Pull

Loaded 12,850 lbs. (5828 kg)

Drive Line Specifications

Engine

Make and Model . . . Cummins B3.9C-80
Fuel No. 2 Diesel
Cycles 4
No. of Cylinders 4
Displacement 239 cu. in. (3.9 L)
Rated Speed 2500 rpm
Max. Gross BHP 80 hp (60 Kw)
Fuel Tank 40 gal. (151.4 L)

Engine Filters

Two-stage dry air cleaner - centrifugal
pre-cleaner with continuous dust ejector
PLUS cleanable and replaceable dry filter
element. Visual service indicator.

Replaceable element-type fuel filter/water
separator. Full-flow replaceable-element
engine oil filter.

Electrical System

Voltage - 12V
Alternator - 63 amp
Battery - 810 Cold Cranking AMP at 0°F

Hydrostatic Drive

5500 PSI (37,923 kpa) closed loop with
piston pump and motors.

All hydraulic connections ORS and Code
62 O-ring flanges.

Integral reservoir with implement
hydraulics.

8 micron suction filter for charge pump.

Self-contained, swashplate design,
variable displacement, over center, piston
pump. Neutral start switch. (Park brake
must also be engaged to start.)

2WD and 4WD inching (524 only).
2WD - 4WD switch on dash (524 only).
Forward, neutral, reverse lever on left
of steering column.

Single foot pedal control provides both
braking and inching for lifting while
maneuvering vehicle.

Electro/hydraulic traction lock valve for
superior tractive effort (524 only).

Axles

Planetary hubs with piston motors on
rear axle (524 only).

Piston motor-driven planetary front axle with
high-bias, limited slip differential.

Brakes

Service - Hydraulic wet disc brake on each
front wheel.

Hydraulic dynamic braking on front axle
and both rear wheels.

Parking Brakes

Spring-applied electro/hydraulic release, fail
safe on both front wheels.

Light on dash indicates when brake is on.

Tires

13:00x24 - G2 type (common wheel).
Optional: 13.00R24 radial tires.

Cab

Certified FOPS/ROPS structure with horn,
back-up alarm and right side rear view mirror.

Steering

Hydraulic power steering with manual
backup. Rear wheel steering, 90° pivot
around either front tire.

Instruments

Volt meter, hour meter, engine oil pressure
gauge, fuel gauge, water temperature
gauge. All gauges protected by clear
acrylic covers.

Controls

Grouped for operator comfort and
convenience.

Boom lift and crowd on single joystick.

Right-hand tilt and sway levers.

Foot throttle.

Floor mounted traction lock switch (524 only).

Hydraulic System-Implement

Single-section gear-direct from engine.

40 gal. (151.4 L) system capacity.

8 micron filter with visual service
indicator and suction strainer.

Lift, crowd, tilt and sway cylinders have safety
checks to prevent dropping of load in the
event of hose or other hydraulic failure.

Accessories & Options

Cab Enclosure

Lockable, split door. Windshield wiper.
Heater & defroster fan.

Light Group

Consists of 2 cab-mounted headlights, 1
backup/tail/stoplight and rotating beacon.

Auxiliary Hydraulic Circuit

Required for all attachments equipped with
cylinders or other hydraulic components.
Consists of valves, controls, hydraulic lines.

Radial Tires

Winch

Left Hand Tilt/Sway Control

Tilt on Joystick

Attachments

Carriage

48" (1.2 m) & 66" (1.7 m)

Slope Pile Carriage

48" (1.2 m) & 66" (1.7 m)

100° Swing Carriage

72" (1.8 m)

Pallet Forks

2" x 4" x 48" (50.8 mm x 101.6 mm x 1.2 m)

Cubing Forks

2" x 2" x 48" (50.8 mm x 50.8 mm x 1.2 m)

Vertical Mast

6' (1.8 m) with 48" (1.2 m)
or 66" (1.7 m) Carriage

Truss Boom With or With Winch

10' (3.0 m)

Bucket

.075 CY (0.57m³) or 1.25 CY (0.95 m³)

Work Platform

Instant Hook

524D

MATERIAL HANDLER

524D-2S (2-Section Boom)

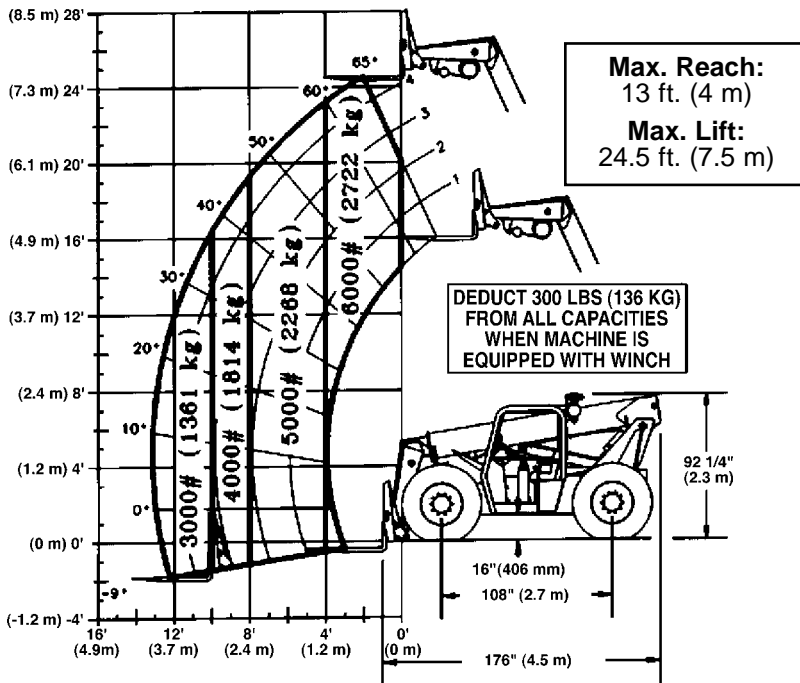

524D-3S (3-Section Boom)

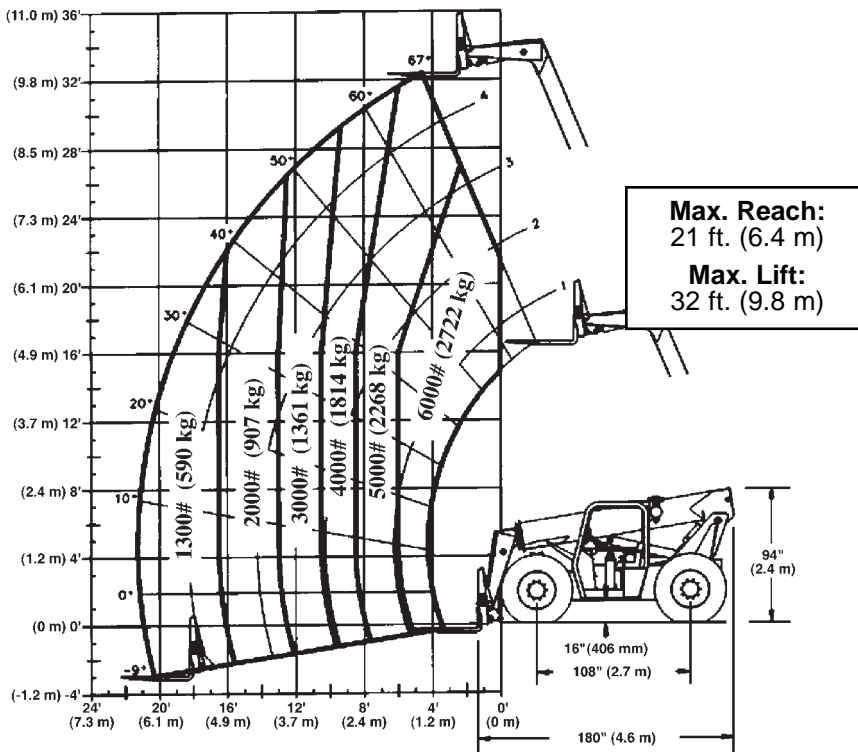

IMPORTANT

Rated lift capacities shown are with machine equipped with carriage and pallet forks and on a firm, level surface with undamaged, properly inflated tires. Machine specifications and stability are based on rated lift capacities at specific boom angles and boom lengths. If specifications are critical, the proposed application should be discussed with your dealer.

DO NOT exceed rated lift capacity loads, as unstable and dangerous machine conditions will result.

DO NOT tip the machine forward to determine the allowable load.

Use only Gradall approved attachments with the proper material handler model/attachment load capacity chart displayed in the operator's cab. OSHA requires all rough terrain forklift operators to be trained according to OSHA 29 CFR 1910.178 (l).

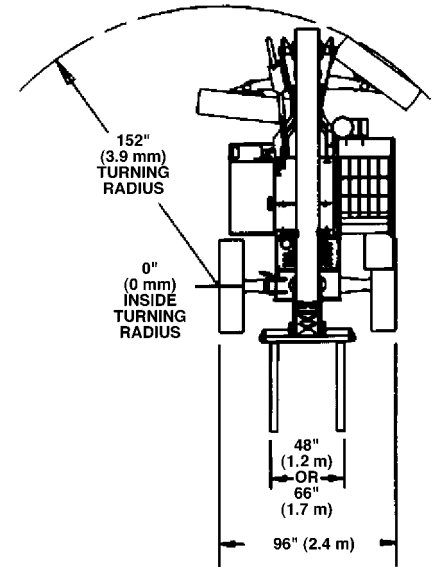

This machine is designed to meet specifications of ASME B56.6b-1998. It is Gradall Policy to continually improve its products. Therefore, designs, materials and specifications are subject to change without notice and without incurring any liability on units already sold. Units shown may have optional equipment. See applicable specifications and price lists for optional equipment.

GRADALL[®]
A JLG COMPANY

The Gradall Company
600 East Chestnut Street, Orrville, Ohio 44667
Phone (330) 339-2211 FAX (330) 684-1029
www.gradall.com